

不锈钢 KLIMA-FLEX 1 锁具装置



Klima-flex 系统专为在隔热门上快速方便安装而设计。可以使用沉头螺母将凸轮固定在轴螺纹区域的任何位置。有关凸轮和开孔的定位，请参见以下图纸和表格。如图纸所示，不锈钢版本有一个特殊开孔。

Klima-flex 锁具装置采用星型锁紧垫圈固定。

内侧选项：所有锁具装置均可采用一个内侧把手、滚子凸轮和连杆。



材质

Cam: 锌合金, 镀铬
 锁头: Steel, chrome plated
 螺母: 铜, 镀锌
 轴: 不锈钢 303
 垫片: 铜, 镀锌

相关产品

把手: 2-310ab, 2-310c
 滑轮锁舌: 2-312cd
 连接杆: 2-313a
 连杆连接部件: 2-313b
 索引编号见网站 industrilas.com

TESTS & STANDARDS

标准: VDI 6022

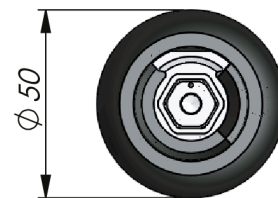
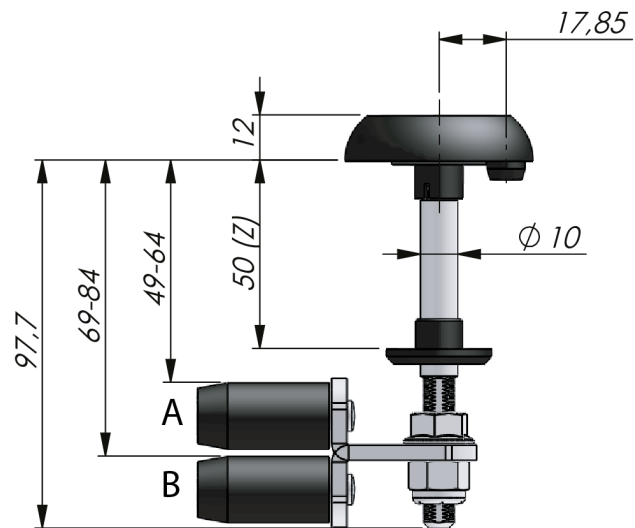

Industrilas
 — When access counts —

Max/Min Measurements for Stainless Cams on Stainless Latching Units - System KLIMA-FLEX

Latching unit	Cam	Grip range *	Cam	Grip range *	Cam	Grip range *
263079-S25-G40	2330S07-R05	A=22-38 B=42-58	2330S07-R08	A=8-25 B=35-51	2330S07-R01 or 2330S07-R06	A=1-17 B=43-59
263079-S30-G40	2330S07-R05	A=27-43 B=47-63	2330S07-R08	A=13-30 B=40-56	2330S07-R01 or 2330S07-R06	A=6-22 B=48-64
263079-S50-G40 **	2330S07-R05 **	A=47-63 B=67-83	2330S07-R08	A=33-50 B=60-76	2330S07-R01 or 2330S07-R06	A=26-42 B=68-84
263079-S60-G40	2330S07-R05	A=57-73 B=77-93	2330S07-R08	A=43-60 B=70-86	2330S07-R01 or 2330S07-R06	A=36-52 B=78-94